

# NAUTILUS FEATHER TOOLS

## Borders

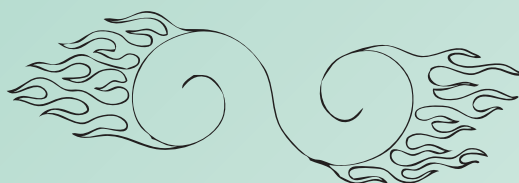

Volume **1**  
3rd Edition

By Sheri Wood

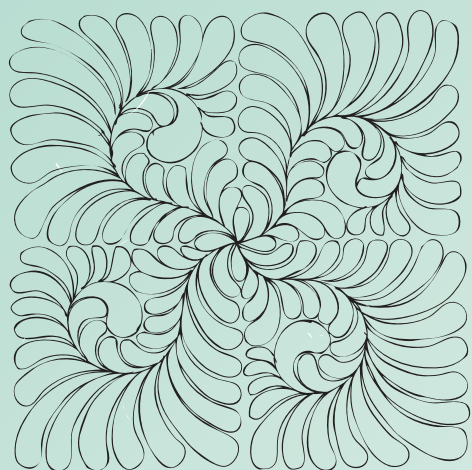

## Blocks

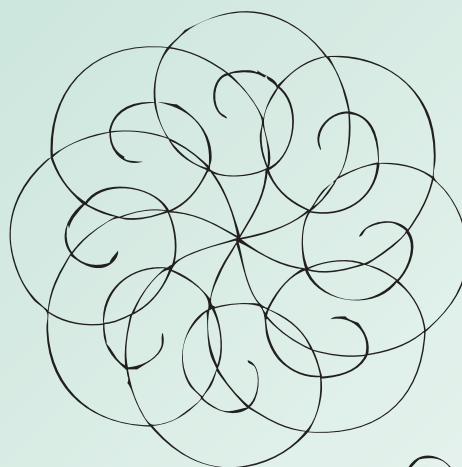

## Corners

## *GENERAL DIRECTIONS*

The NEW Nautilus Baseline Tools will help you make baselines for many different borders, corners, and blocks. Simply draw or stitch a baseline and embellish with feathers, spirals, leaves or anything you can imagine. Whether you are quilting on a longarm, midarm, shortarm, or domestic machine or by hand you can use the Nautilus Baseline Tools to create designs that are perfect for your quilt.

When using the Nautilus Baseline Tools for quilting by hand or by domestic machine, use a template tester\* to draw the baseline on the quilt or on to paper to transfer to the quilt by your preferred methods. You can use a mechanical pencil with the regular template tester. The new template tester with the larger diameter center hole can be used with the blue water soluble markers for fabrics.

When using the Nautilus Baseline Tools with a quilting machine; whether longarm, midarm, or shortarm, use the extended base suggested for your machine. The appropriate template foot for your machine is required. Check with your quilting machine dealer if you have any questions about your machine's accessories.

The Nautilus Baseline Tools are easy and versatile tools to work with, but as with any new tool or technique, practice is encouraged before you start quilting. As always patterns are only suggestions, and trying new designs by drawing them is encouraged.

If you have trouble with the tools slipping while you are quilting, try using the Grip Stop Dots (available from Quilter's Rule) or 505 Temporary Adhesive Spray.

Directions for the designs can be used with any size of the Nautilus Spiral Tools.

\*Template testers are available from Quilter's Rule free of charge. Send a self-addressed stamped envelope to:

Quilter's Rule  
Template Tester/Nautilus Tools  
N6323 Berlin Road  
Green Lake, WI 54941

Or look for us at one of the many shows we attend throughout the United States. Check our web site [www.quiltersrule.com](http://www.quiltersrule.com) for show calendar.

As you get more comfortable with the Nautilus Baseline Tools (Nautilus Feather, Feather Chunky, Spiral, and Delta), experiment with other arrangements, embellishments, and combinations of tools. Try adding them to templates you already own... add spiral on the points of a star or pinwheel. Stitch one inside a large paisley or on the end of the paisley. How about with hearts, or inside a square; the possibilities are limited only by your imagination.

Ideas and inspiration for designs are all around us. Many of the embellishment designs shown in the booklet have been inspired by nature and influenced by the quilts I've seen, classes I've attended, in architectural details or clip art books. Remember patterns are only suggestions! Through this booklet and the Nautilus Baseline Tools, I am happy to share with you designs I have been working with. I encourage you add your ideas to these and stitch designs as individual as you!

Thank you,

*Sheri Wood*

The Nautilus Feather Tool is etched with registration lines that divide the tool into 8 sections. The sections are numbered starting from the open or tail end. The registration lines are used to help you keep the baseline even. The baseline is your stitching line.

**General Terms:**

- Registration lines - Etched lines on the tool
- Baseline - Stitched lines
- Center guide line - Marked lines on the quilt

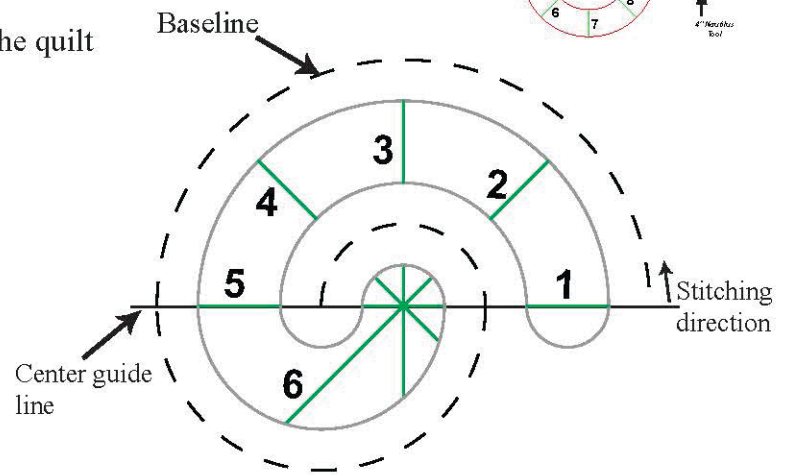
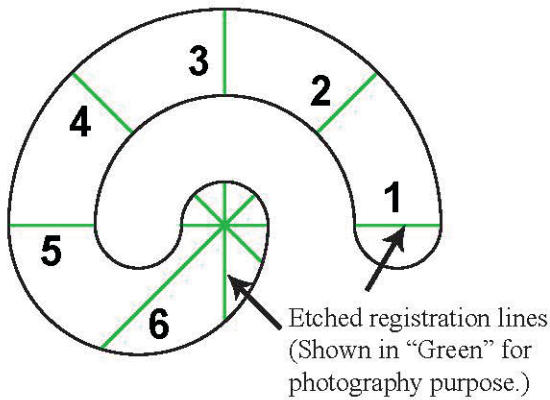
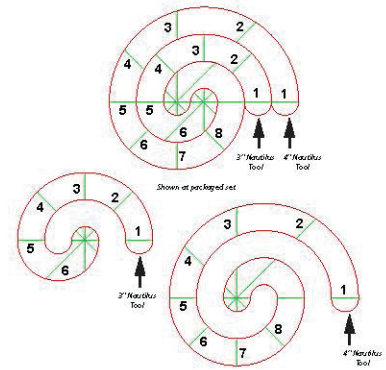

For borders, mark a center guide line on the lengthwise center of the border with an appropriate marking tool. My favorites include Hancy’s Ultimate Iron Off Chalk Powder (that I put into a chalk pen – the kind that you can refill and has a wheel on the bottom) or a blue water soluble marker. **ALWAYS** test your choice of marking methods. Mark a widthwise center guide line at the center of each border and the diagonal of each corner. For blocks and other spaces, mark whatever lines needed to keep the baselines even.

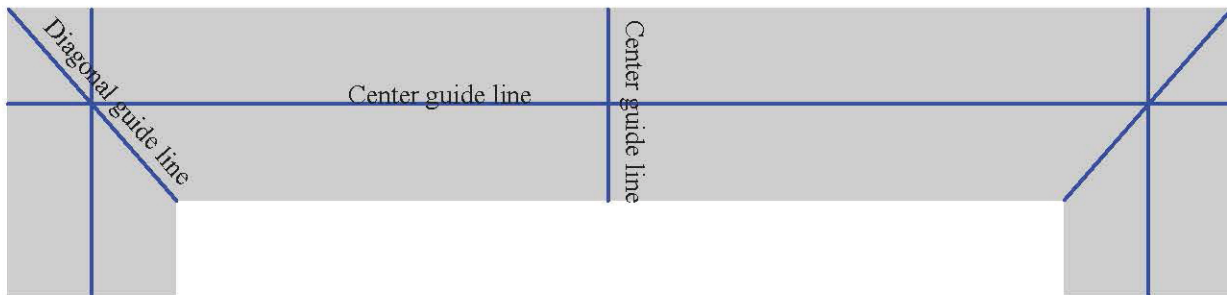

# 1 and 5 Straight Border

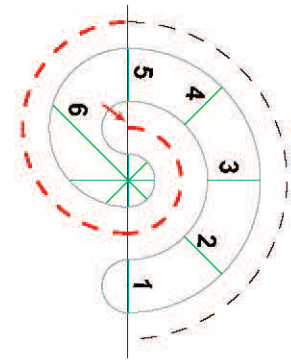
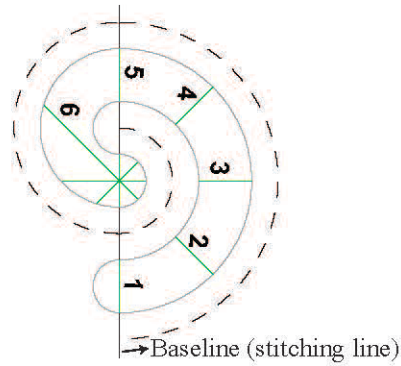
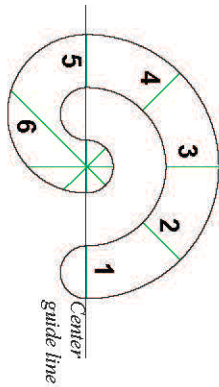

1. Place the Nautilus Feather Tool on the lengthwise center guide line mark of the border. Position the #1 and #5 registration lines of the tool on the center guide line.

2. Bring up your bobbin thread and anchor your stitching line. Begin sewing around the outside edge of the Nautilus Feather Tool, adjusting your hand position as necessary, until you stitch to the center of the tool.

3. Backtrack your stitching line until you reach the top of the tool (#5 registration line) and the center guide line of the border.

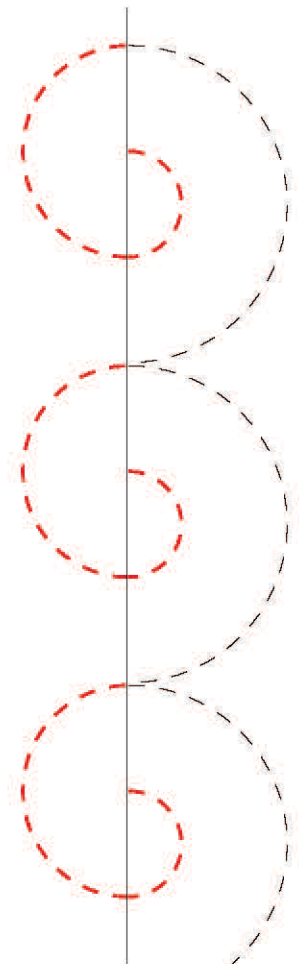
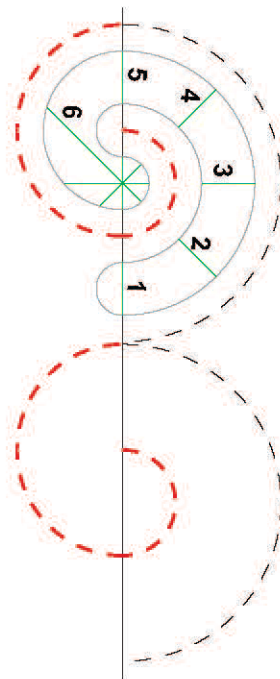
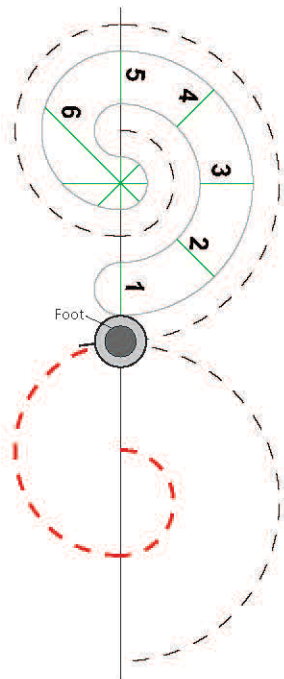

4. With needle down on the center guide line, move the Nautilus Feather Tool so #1 registration line butts up against the foot. Keep the Nautilus Feather Tool facing the same direction as before and begin stitching around the tool until you reach the center.

5. Backtrack your stitching out to the top center (#5).

6. Continue as far as you need to complete your border or until you need to reposition the quilt.

7. Embellish if desired.

**The RED stitching line indicates "Backtrack" stitching**

# 1 and 5 Alternating Border

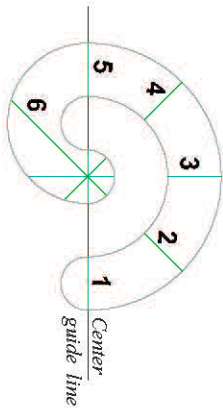

1. Place the Nautilus Feather Tool on the lengthwise center guide line mark of the border. Position the #1 and #5 registration lines of the tool on the center guide line.

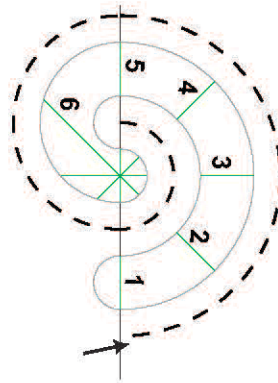

2. Bring up your bobbin thread and anchor your stitching line. Begin sewing around the outside edge of the Nautilus Feather Tool, adjusting your hand position as necessary, until you stitch to the center of the tool.

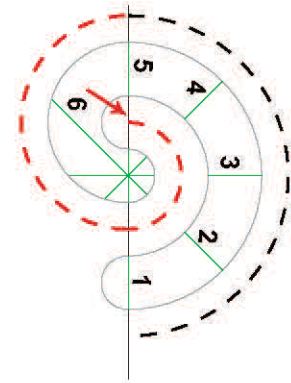

3. Backtrack your stitching line until you reach the top of the tool (#5 registration line) and the center guide line of the border.

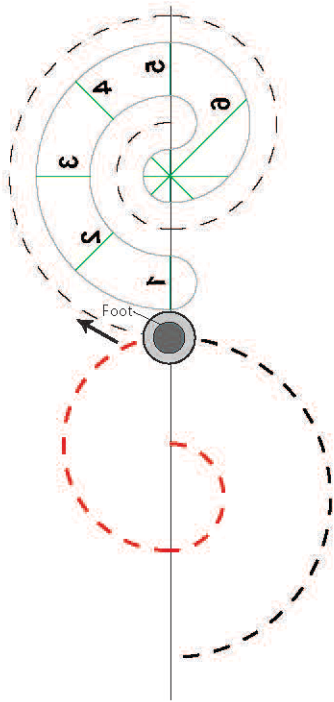

4. Flip the Nautilus Feather Tool over so it faces the opposite direction as before and #1 registration line is at the foot.

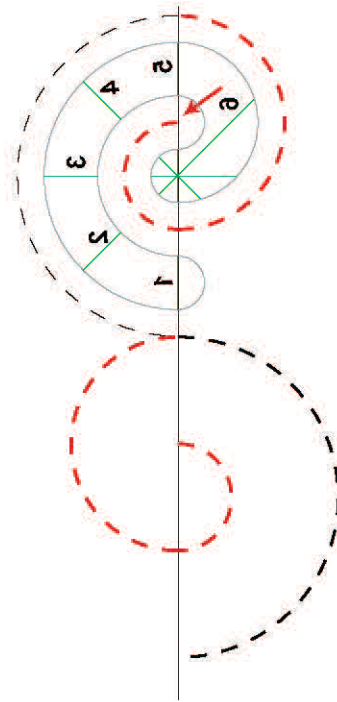

5. Begin stitching around the tool until you reach the center. Backtrack out to registration line #5.

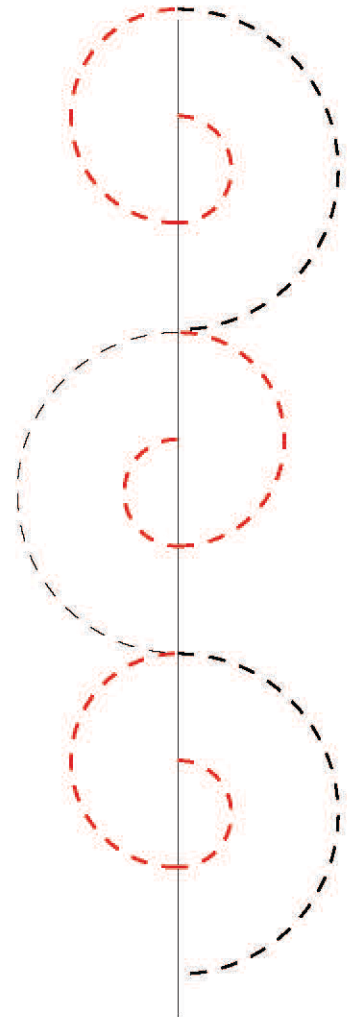

6. Continue alternating the direction of the tool, stitching until you finish your border or need to reposition the quilt.

7. Embellish if desired.

**The RED stitching line indicates "Backtrack" stitching**

# *Embellishing Ideas*

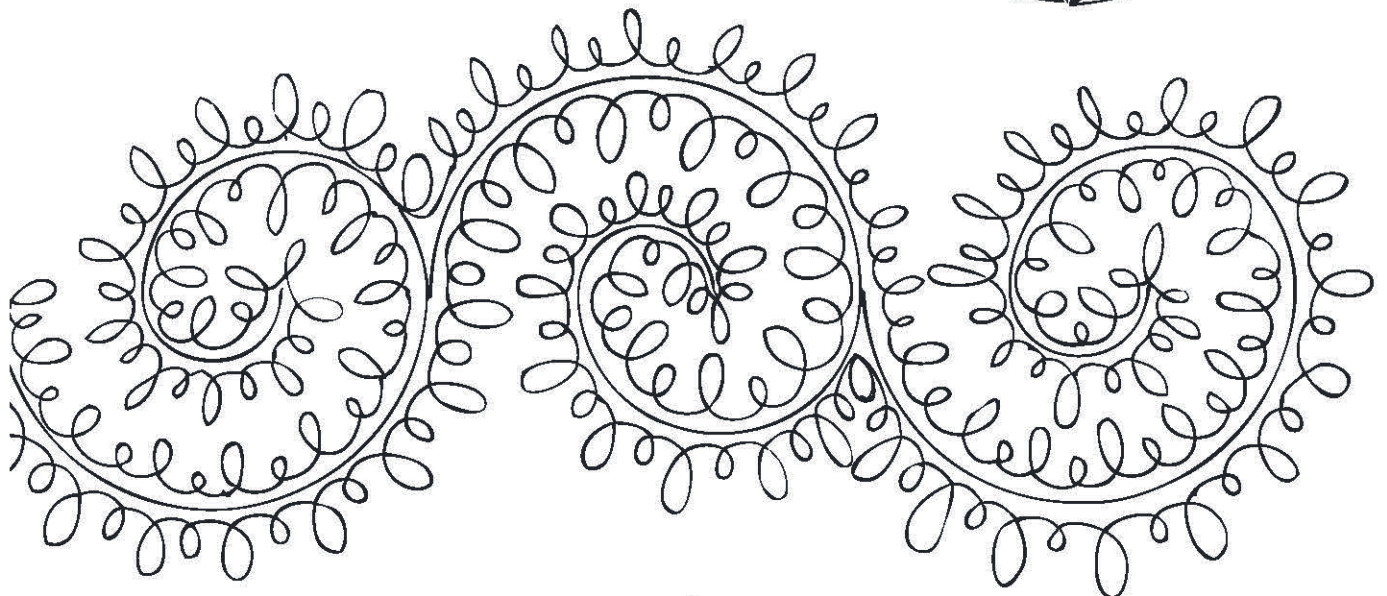
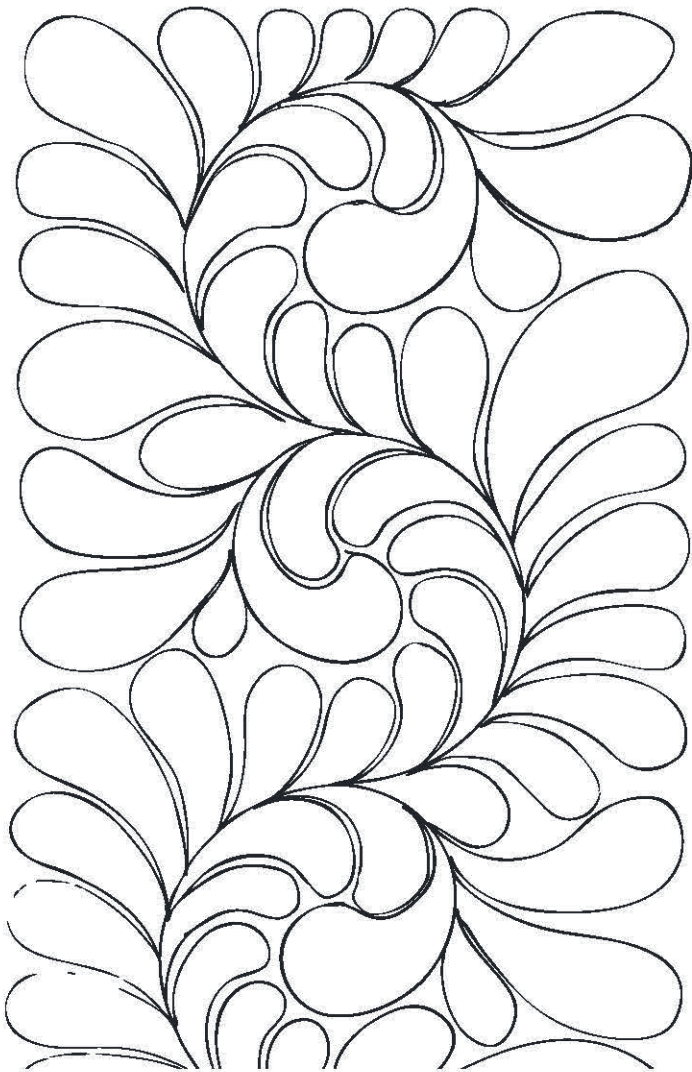

# 1 and 5 Stretched Border

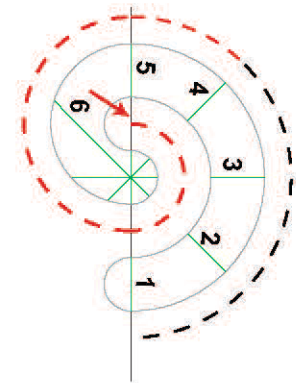
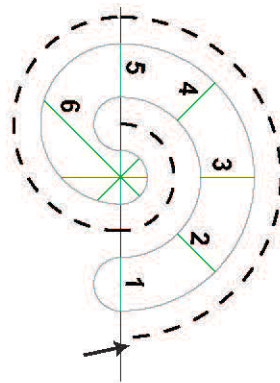
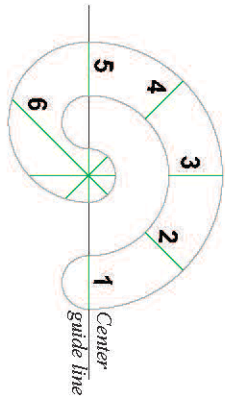

1. Place the Nautilus Feather Tool on the lengthwise center guide line of the border. Position the #1 and #5 registration lines of the tool on the center guide line.

2. Bring up your bobbin thread and anchor your stitching line. Begin sewing around the outside edge of the Nautilus Feather Tool, adjusting your hand position as necessary until you stitch to the center of the tool.

3. Backtrack your stitching line until you reach the #4 registration line.

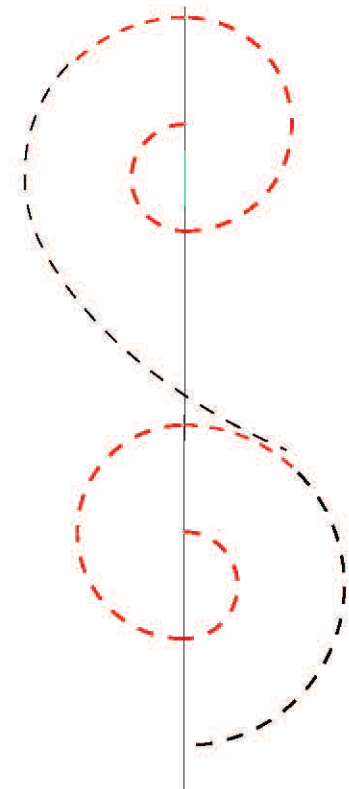
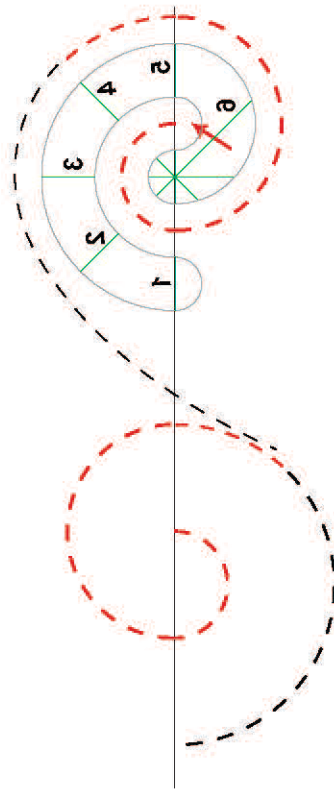
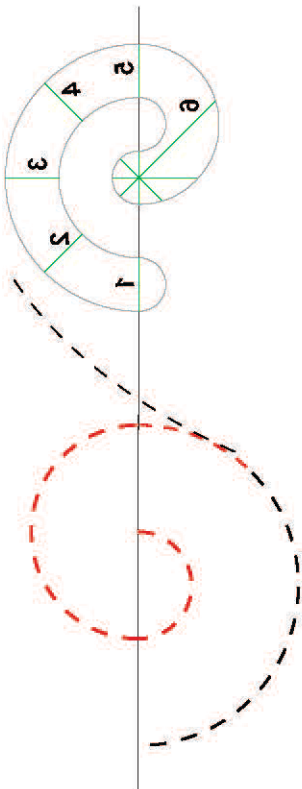

4. Move the Nautilus Feather Tool so #1 registration line is on the center guide line of the border but is about 2 inches (or more depending on your design) from the top of the baseline you just stitched. Flip the Nautilus Feather Tool so it faces the opposite direction as before and stitch a line from #4 (where you stopped on the last baseline) to about #2 registration line.

5. Stitch around the tool until you reach the center, backtrack out to about #4 registration line again.

6. Reposition the tool as before and continue as far as you need to complete your border, alternating the direction of the tool or until you need to reposition the quilt.

7. Embellish if desired.

***The RED stitching line indicates "Backtrack" stitching***



# *Embellishing Ideas*

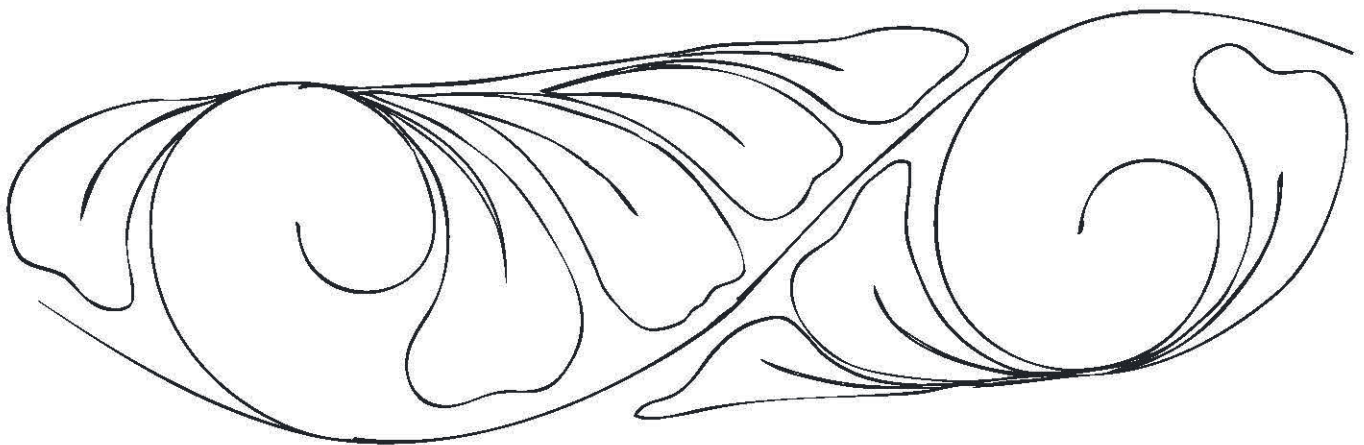
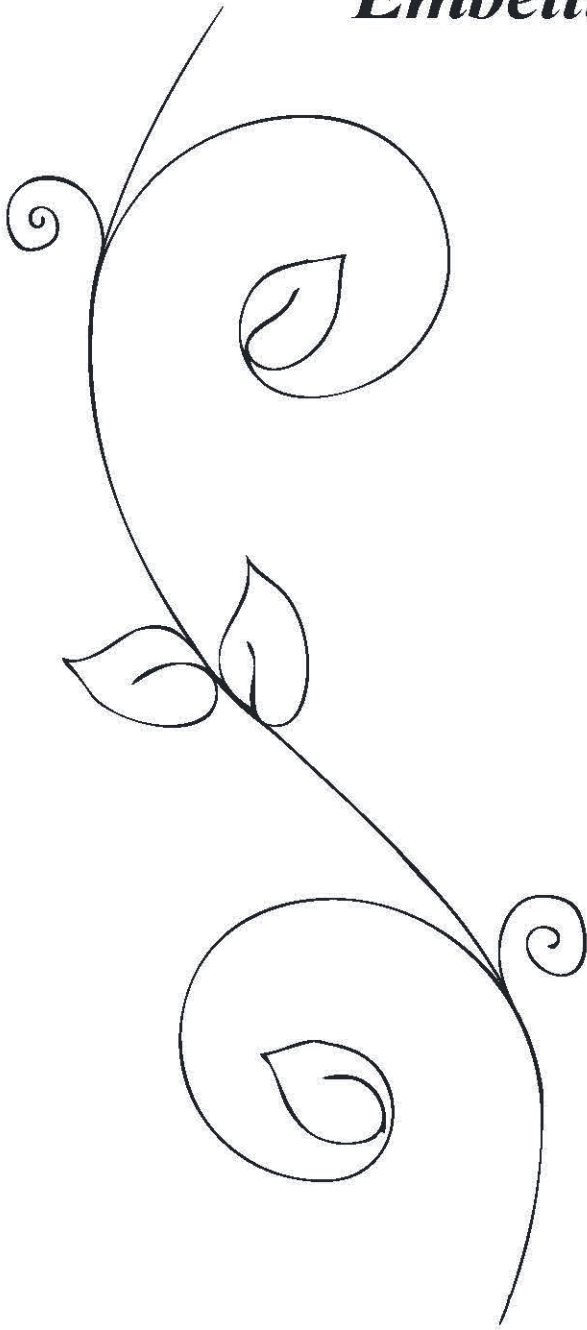

# 1 and 4 Alternating Border

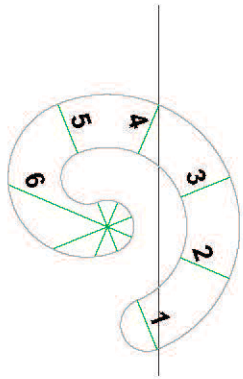

1. Place the Nautilus Feather Tool on the lengthwise center guide line of the border. Position the #1 and #4 (at outside edge of tool) registration lines of the tool on the center guide line.

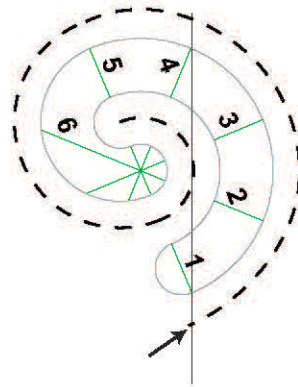

2. Bring up your bobbin thread and anchor your stitching line. Begin sewing around the outside edge of the Nautilus Feather Tool, adjusting your hand position as necessary until you stitch to the center of the tool.

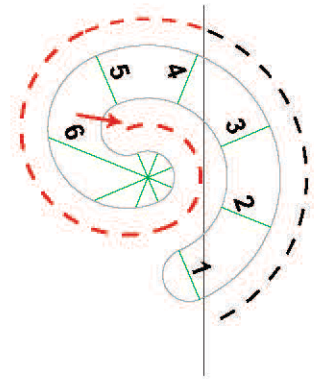

3. Backtrack your stitching line until you reach the #4 registration line and the center guide line of the border.

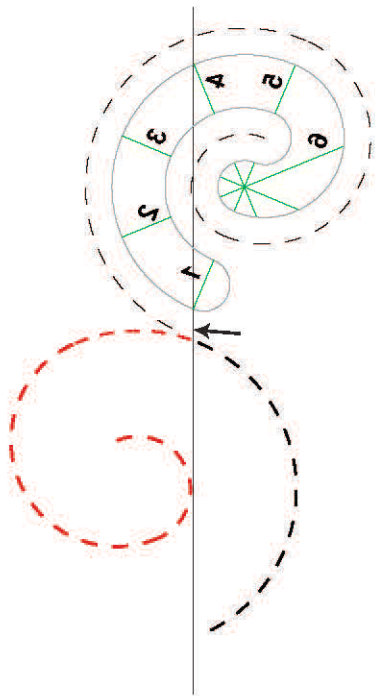

4. Move the Nautilus Feather Tool so #1 registration line is at the foot and it faces the opposite direction as before. Stitch around outside edge of the tool until you reach the center.

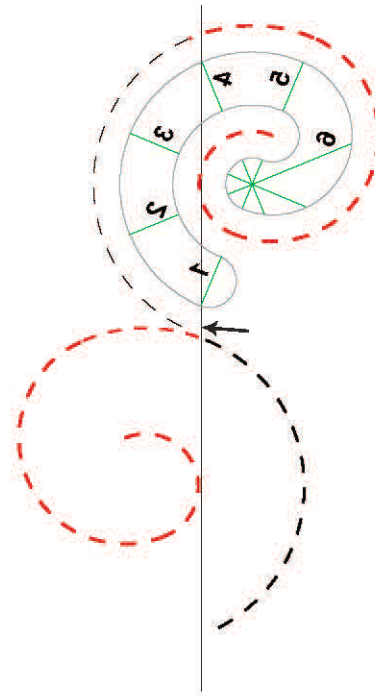

5. Backtrack out to the #4 registration line.

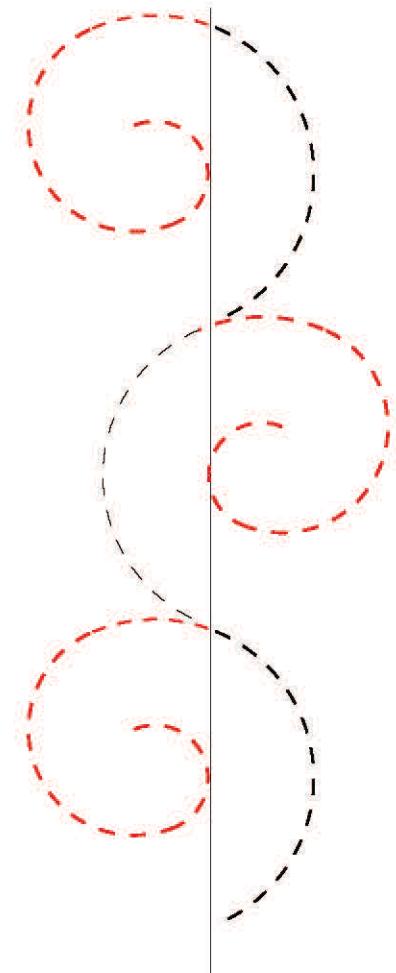

6. Continue stitching, alternating directions of the tool each time and keeping #1 at the bottom until you need to reposition the quilt or complete the border.

7. Embellish if desired.

**The RED stitching line indicates "Backtrack" stitching**

# *Embellishing Ideas*

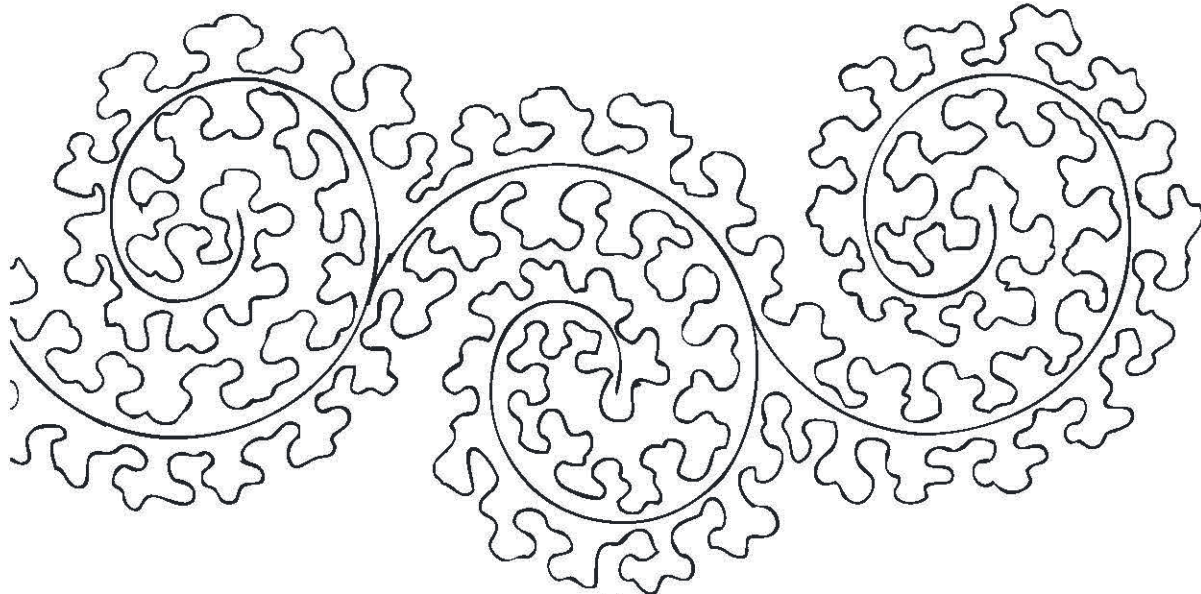
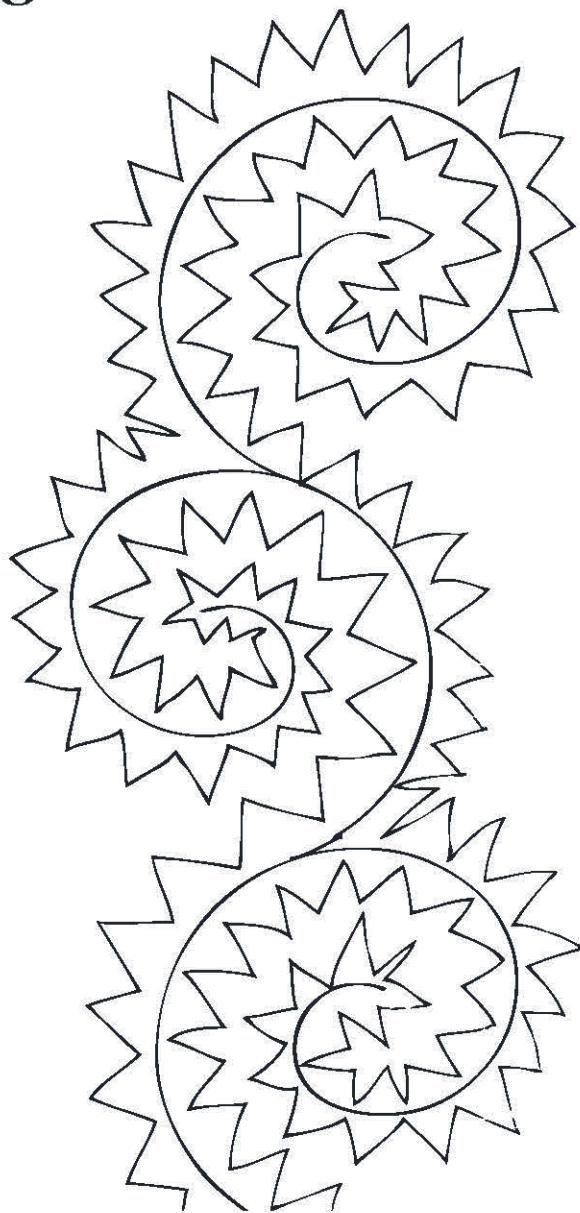
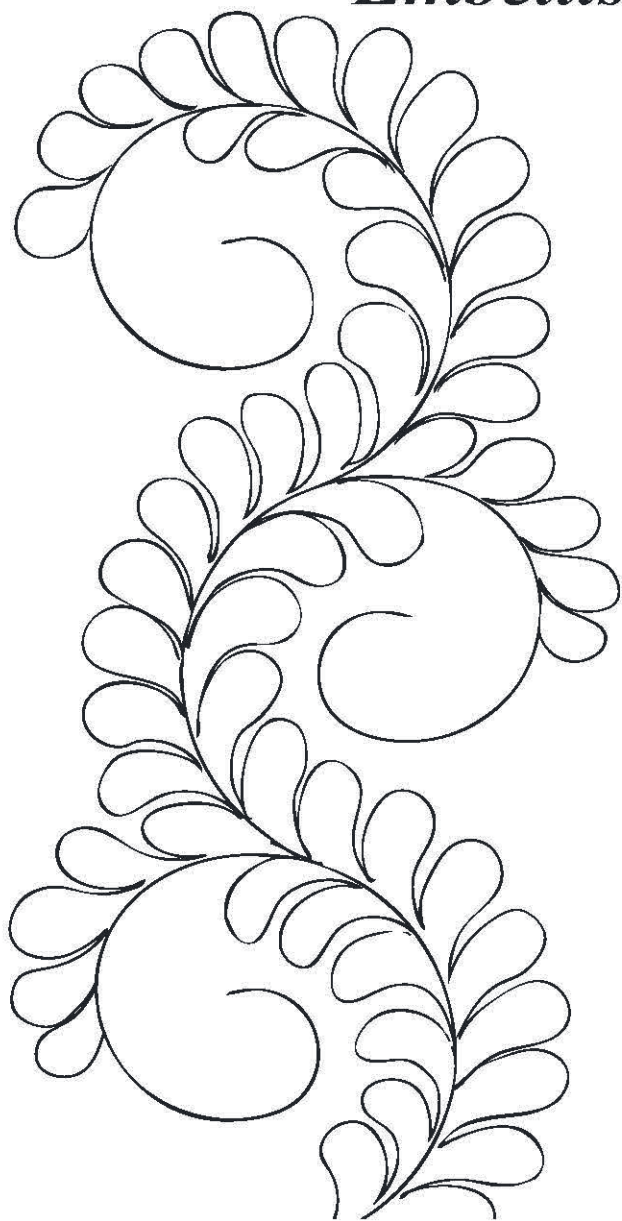

# 1 and 3 Alternating Border

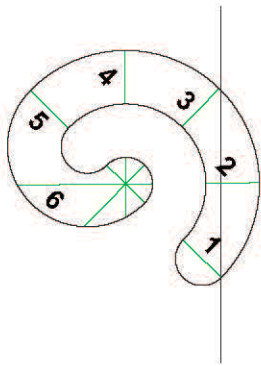

1. Place the Nautilus Feather Tool on the lengthwise center guide line of the border. Position the #1 and #3 (at outside edge of tool) registration lines of the tool on the center guide line.

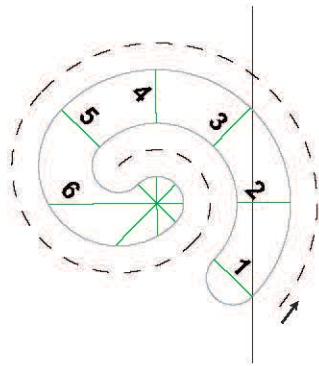

2. Bring up your bobbin thread and anchor your stitching line. Stitch around outside edge of the Nautilus Feather Tool, adjusting your hand position as necessary, until you stitch to the center of the tool.

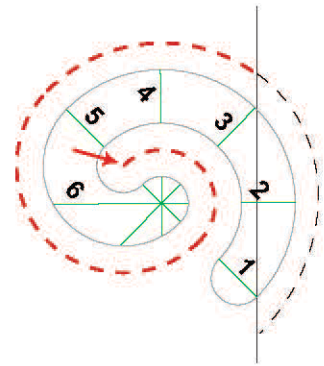

3. Backtrack your stitching line until you reach #3 registration line and the center guide line of the border.

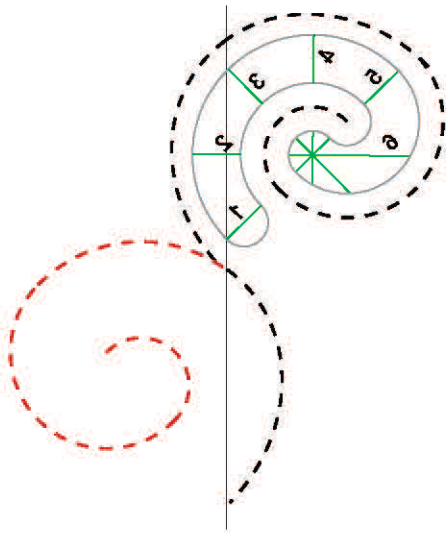

4. Flip the Nautilus Feather Tool over so it faces the opposite direction as before and the #1 registration line is at the foot. Stitch around the tool until you reach the center.

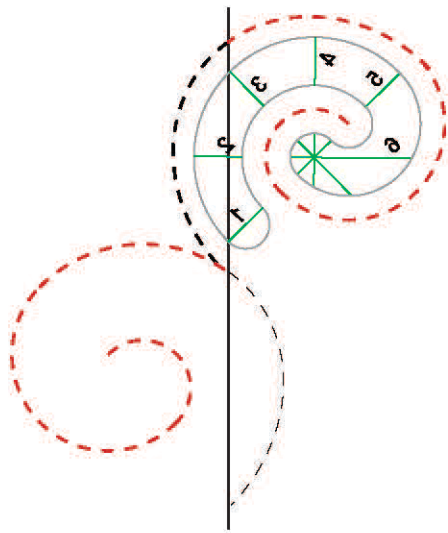

5. Backtrack out to #3 registration line.

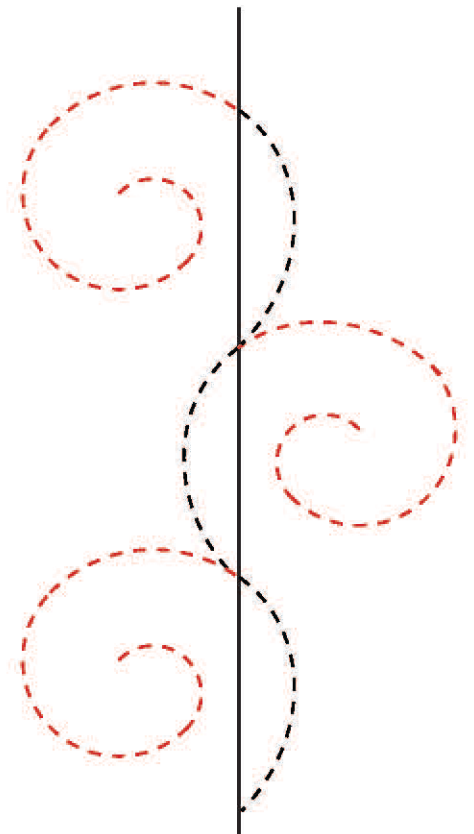

6. Continue stitching, alternating directions of the tool each time as far as you need to complete you border or until you need to reposition the quilt.

7. Embellish if desired.

**The RED stitching line indicates "Backtrack" stitching**

# *Embellishing Ideas*

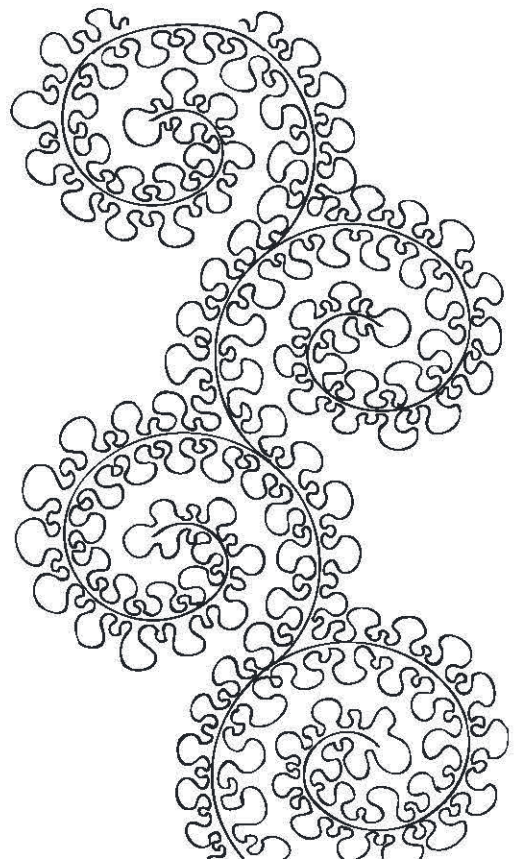
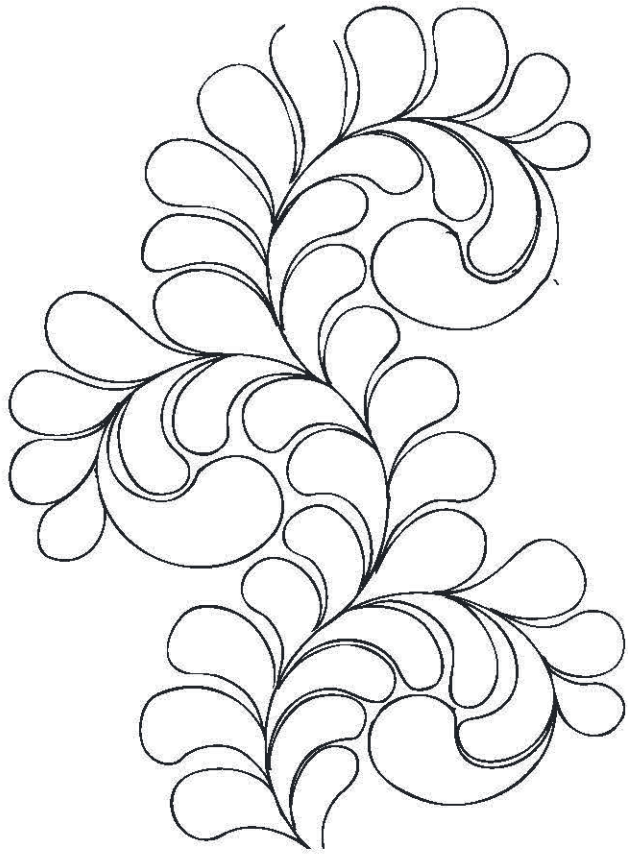

# *Mardi Gras Border*

1. Draw<sup>1</sup> the baseline onto the border area using the directions for the 1 & 3 Alternating Border directions.

For many quilts you can mark the baseline on the border of the entire quilt top before loading it into the quilting machine.

2. Stitch the baseline with small circles to resemble beads.

3. Stitch “hook” feathers to the baseline.

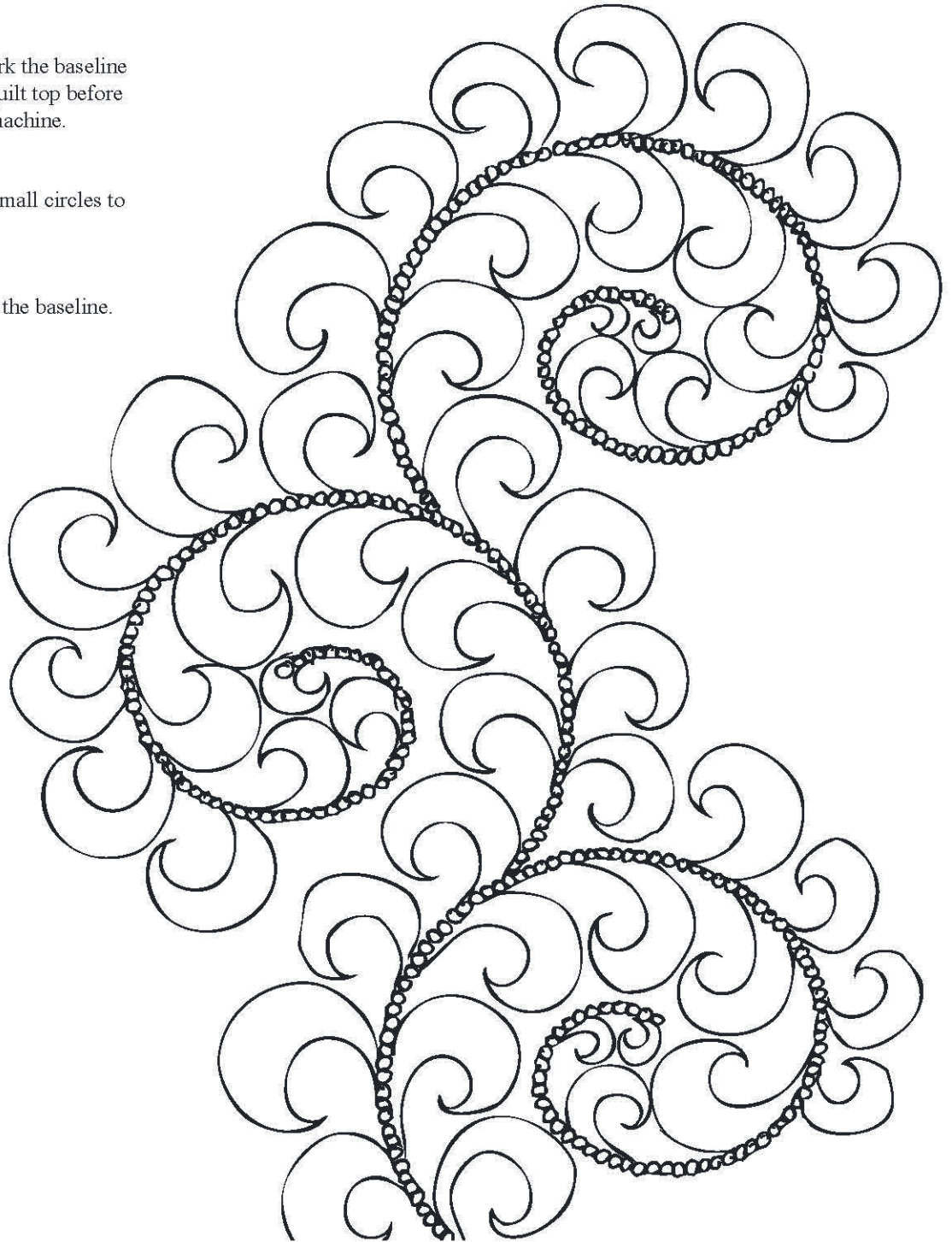

---

<sup>1</sup> Draw the baseline on the border by placing the Nautilus Feather Tool and a template tester on the center guide line using one of the transfer methods described in the “General Directions”.

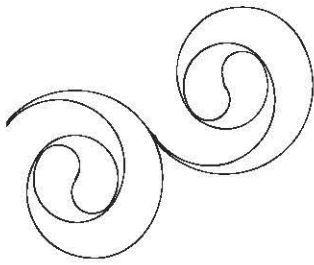

# Twisted Ribbon Border

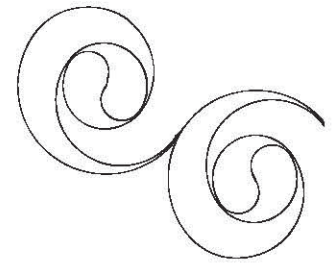

The Twisted Ribbon Border is a beautiful border using both the 3 and 4 inch Nautilus Feather Tools. This border design can also be stitched with the 6 and 7 inch Nautilus Chunky Feather Tools.

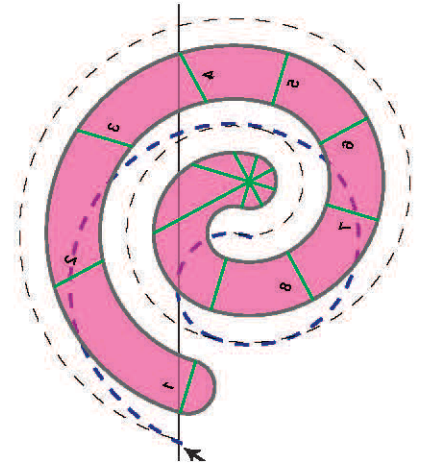
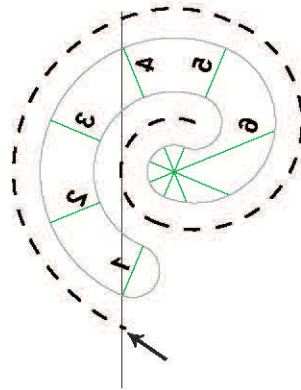
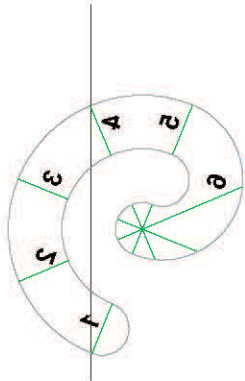

1. Place the smaller tool with #1 and #4 registration lines on the lengthwise center guide line of the border. (This also works using #1 and #3 registration lines.)

2. Bring up bobbin thread and anchor stitching line. Stitch around the outside edge of tool to the center.

3. Drop needle, stop the machine and remove the smaller tool. Place the larger tool so the needle is at the center of the tool and #1 registration line is on the center guide line at bottom. Stitch out to #1 of the tool.

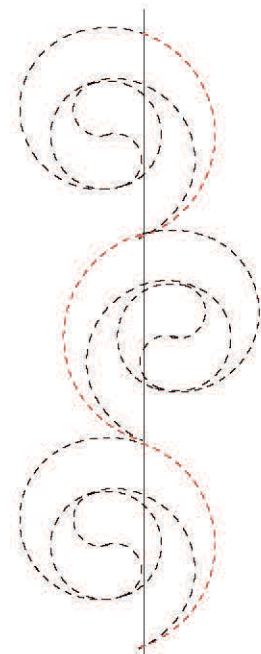
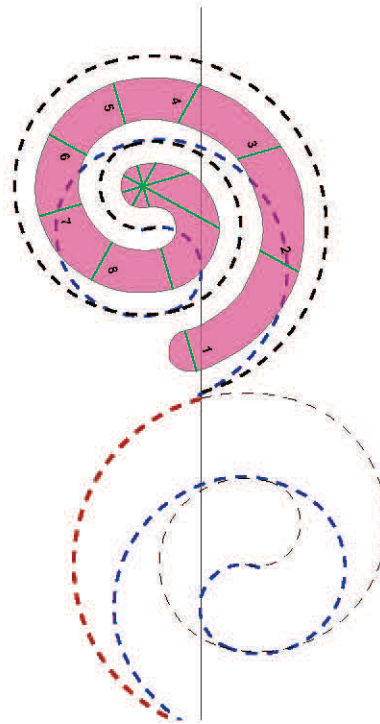
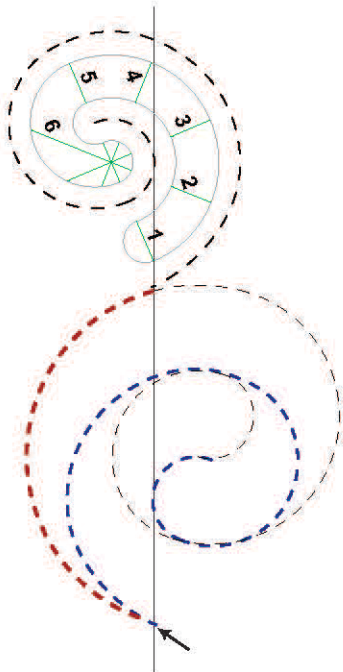

4. Backtrack the stitching around the outside up to center guide line on the border. Place the smaller tool with #1 at bottom and facing the opposite way as before. Stitch to center of the tool.

5. Drop the needle and stop the machine. Remove smaller tool and place the larger tool in position and stitch back to bottom. Backtrack stitching line to center line.

6. Continue stitching design until completing your border or you need to reposition the quilt.

**The RED stitching line indicates "Backtrack" stitching**

# Corner #1

This is the easiest corner to make and can be used with any of the border designs. When you get to a corner, continue the design around the corner, adjusting the direction to fit the border. Embellish as you desire.

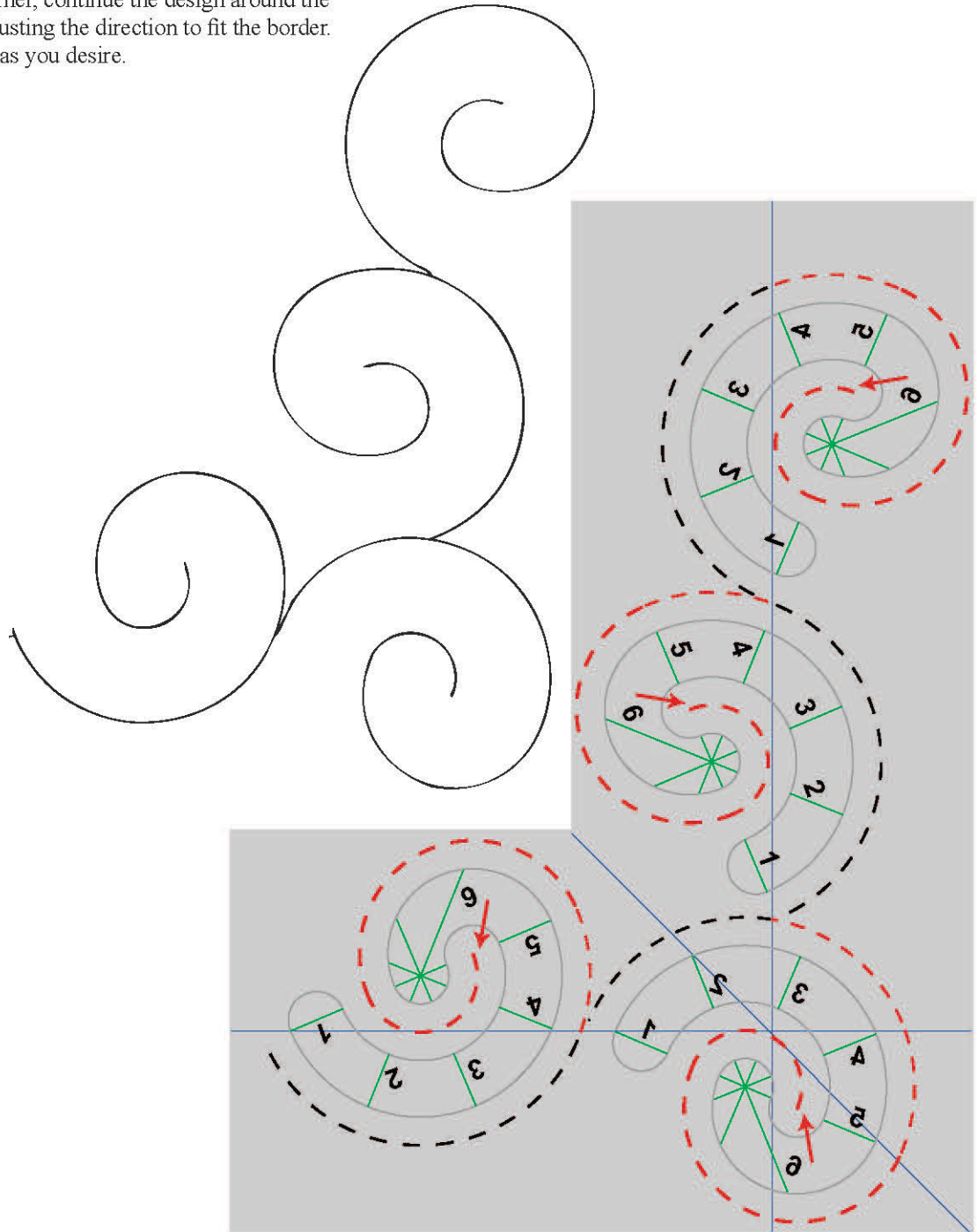

*The RED stitching line indicates "Backtrack" stitching*



## Corner # 2

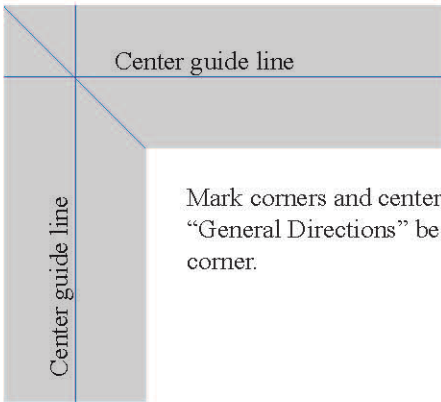
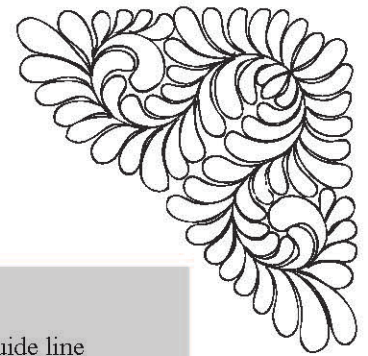
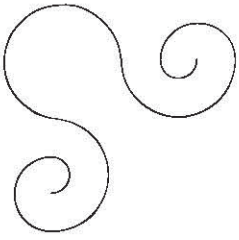

Mark corners and center of border as in the "General Directions" before stitching this corner.

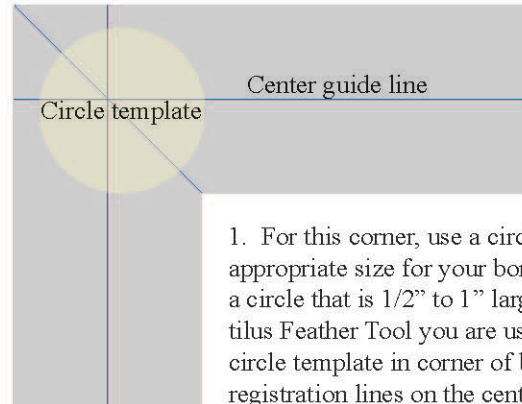

1. For this corner, use a circle template (an appropriate size for your border). Try using a circle that is 1/2" to 1" larger than the Nautilus Feather Tool you are using. Position the circle template in corner of border with the registration lines on the center guide lines and diagonal line of border. (When using this corner start the border in the corner and work to the centers of each border or the opposite corner of the quilt.)

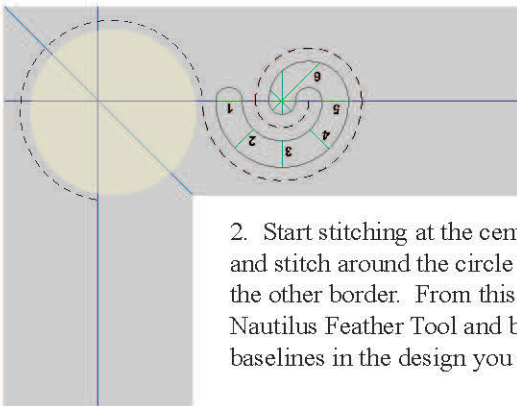

2. Start stitching at the center of one border and stitch around the circle to the center of the other border. From this point use the Nautilus Feather Tool and begin the border baselines in the design you selected.

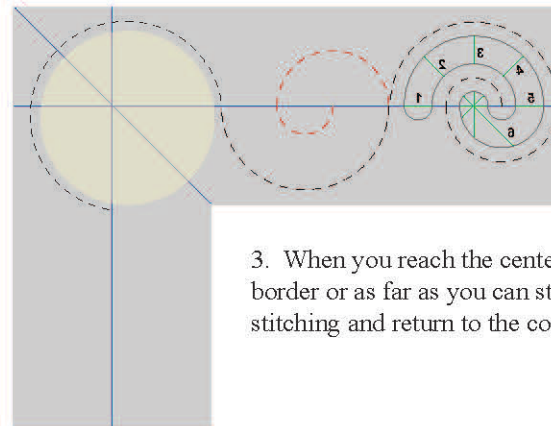

3. When you reach the center of the border or as far as you can stitch, end your stitching and return to the corner.

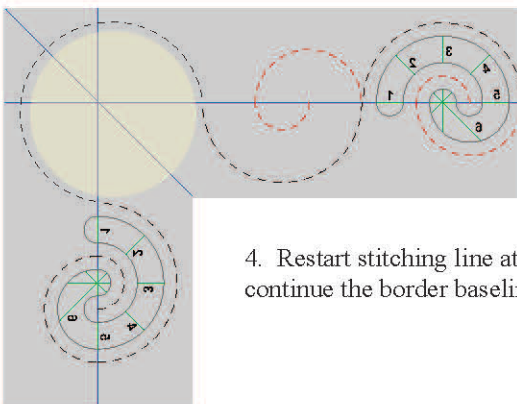

4. Restart stitching line at the corner and continue the border baseline design.

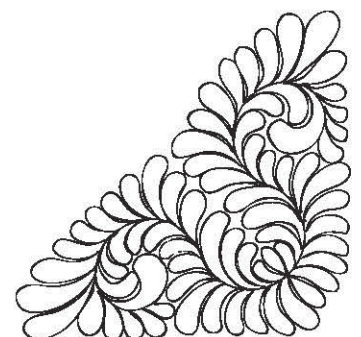
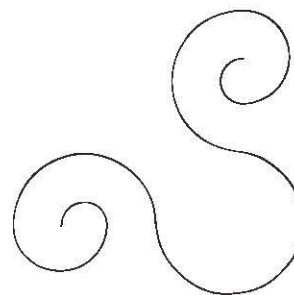

**The RED stitching line indicates "Backtrack" stitching**

# Corner # 3

For this corner design you will start your border baseline at the corner and work to the center of each border. This is a good choice of corners for the Mardi Gras or the Twisted Ribbons border designs. Mark center of border and corners as in the “General Directions”.

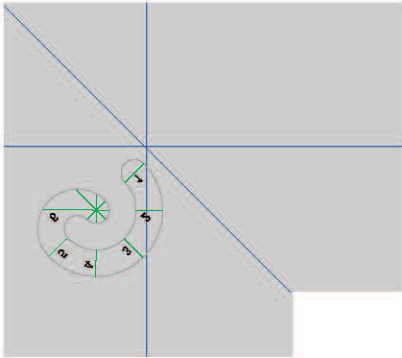

1. Place the Nautilus Feather Tool at the corner with #1 registration line on the point where the center guide line and diagonal lines of border intersect. Use #2, 3, 4, or 5 for other point depending on how open you want the corner to be.

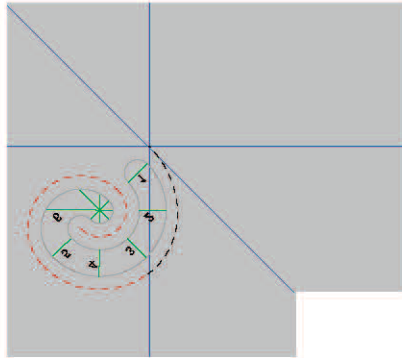

2. Begin stitching around the tool to center, backtrack to center guide line of border. Reposition the tool and continue stitching the design you have selected, until you reach the center of the border or you need to reposition the quilt.

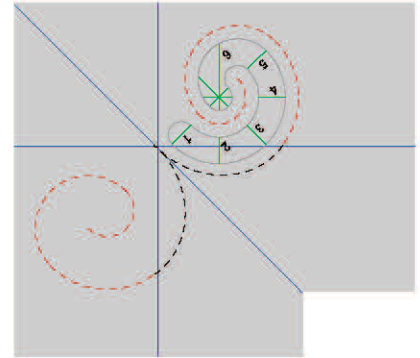

3. Restart stitching line at the corner and continue the baseline design on other border.

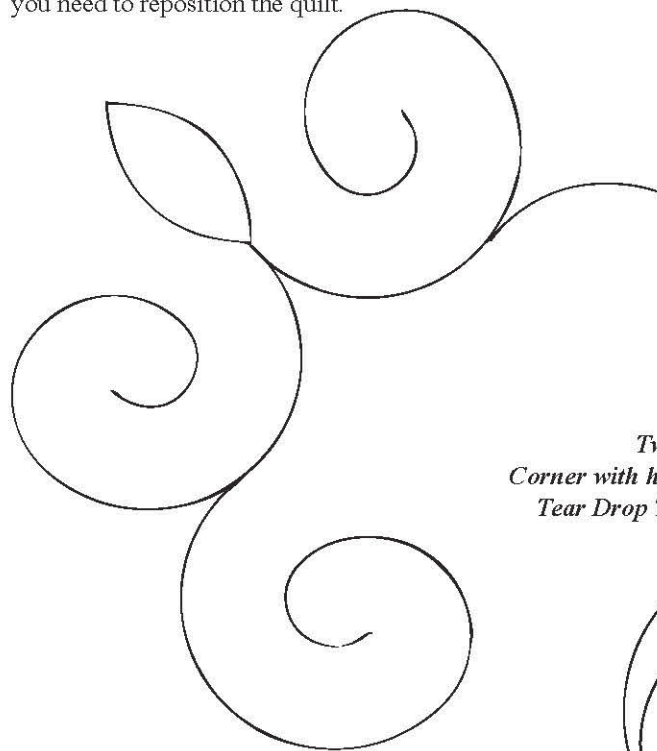
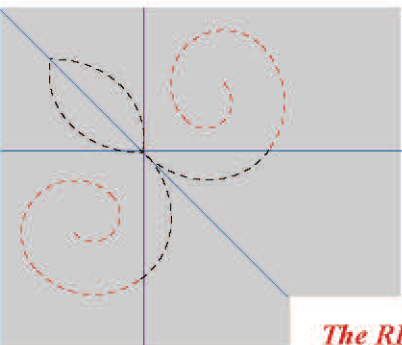
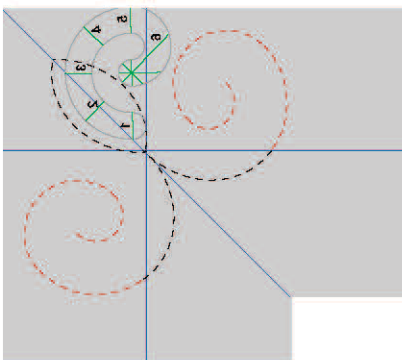
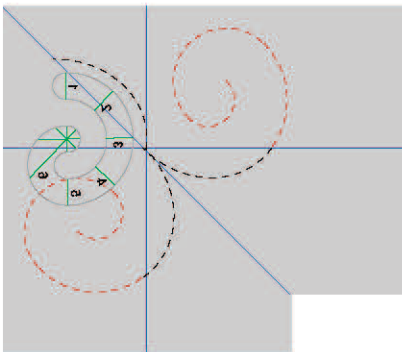

*Twisted Ribbon  
Corner with heart using Quilter's Rule  
Tear Drop Template for the heart.*

4. Embellish the corner as desired.

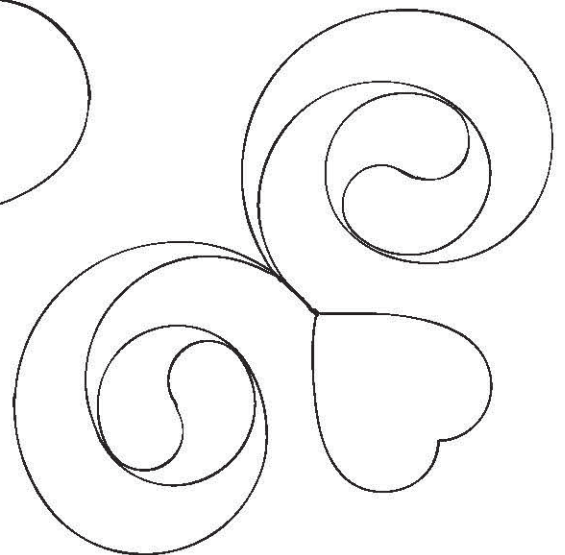

**The RED stitching line indicates “Backtrack” stitching**

## *Blocks and Flourishes*

You can also use the Nautilus Feather Tools to make baselines for whatever shape space you need to fill. Whether you need to fill a block, sash, or any sized space, here are some suggestions for baselines to try.

As always, leave them unadorned or embellish the baselines as you desire.

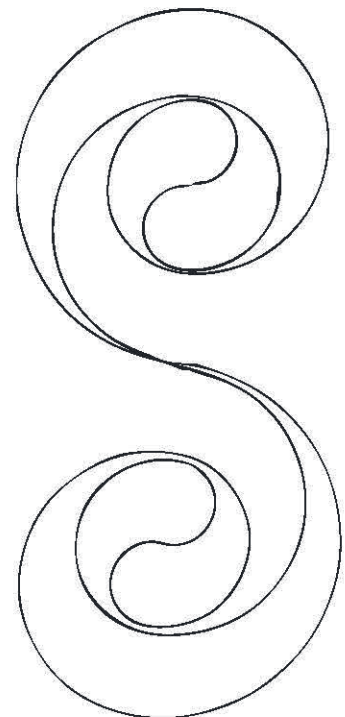
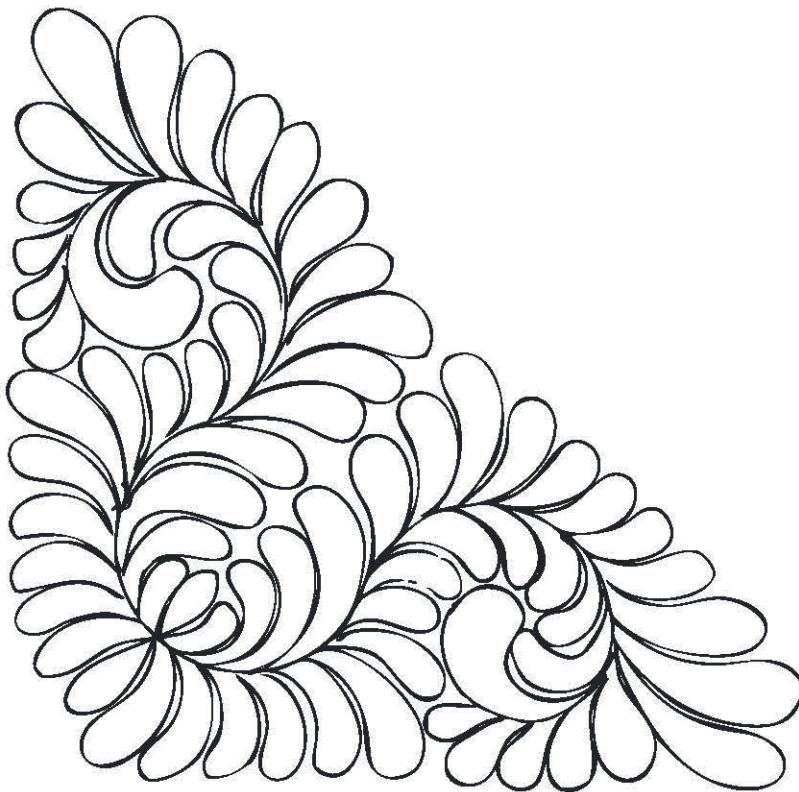
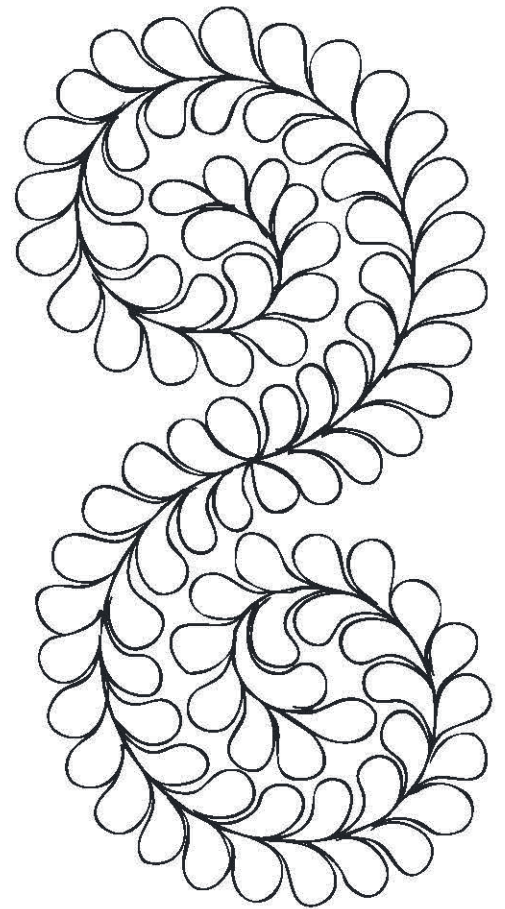
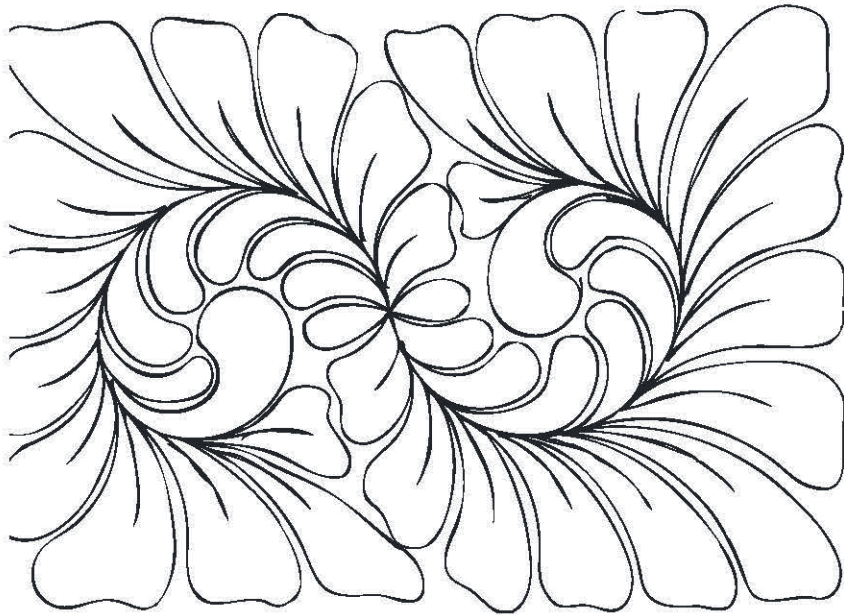

# *Embellishing Ideas*

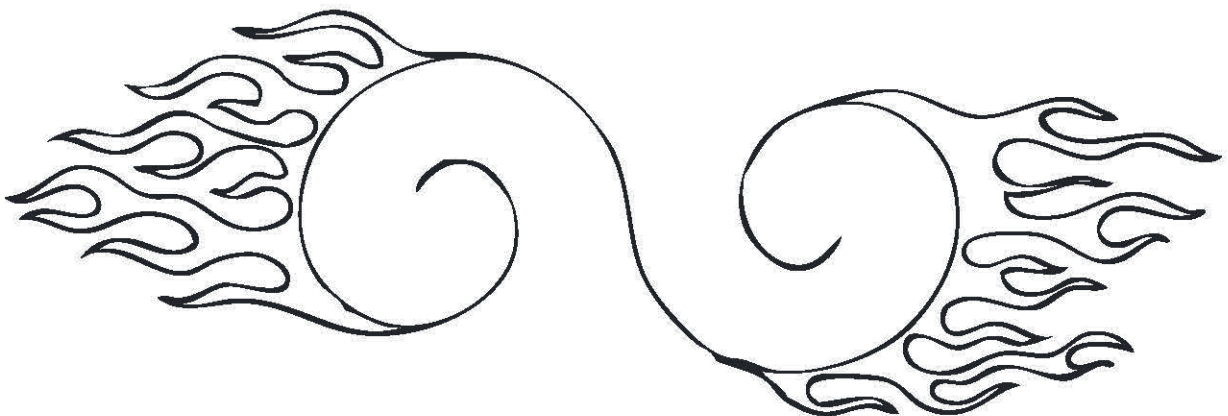
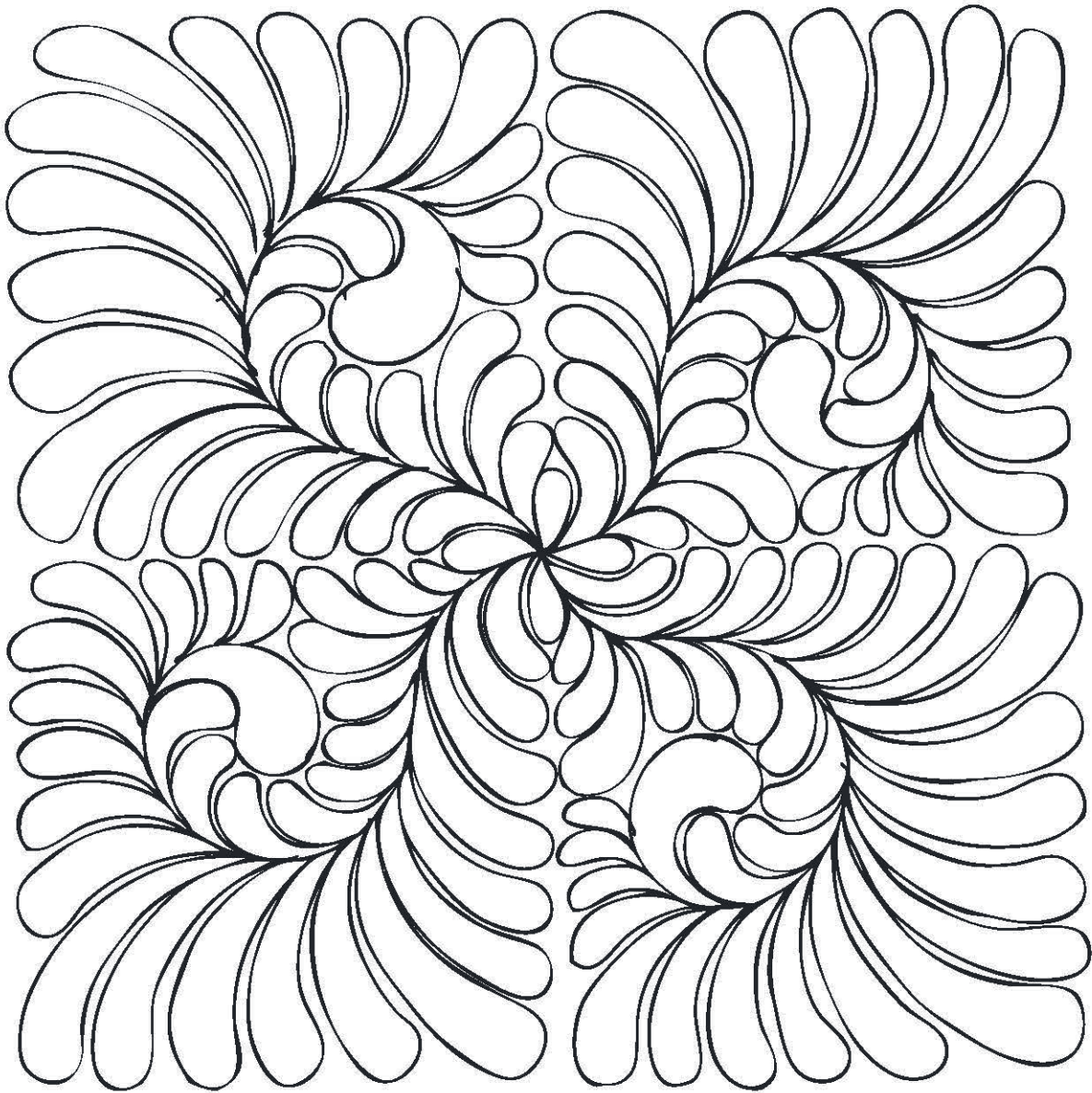

# *Embellishing Ideas*

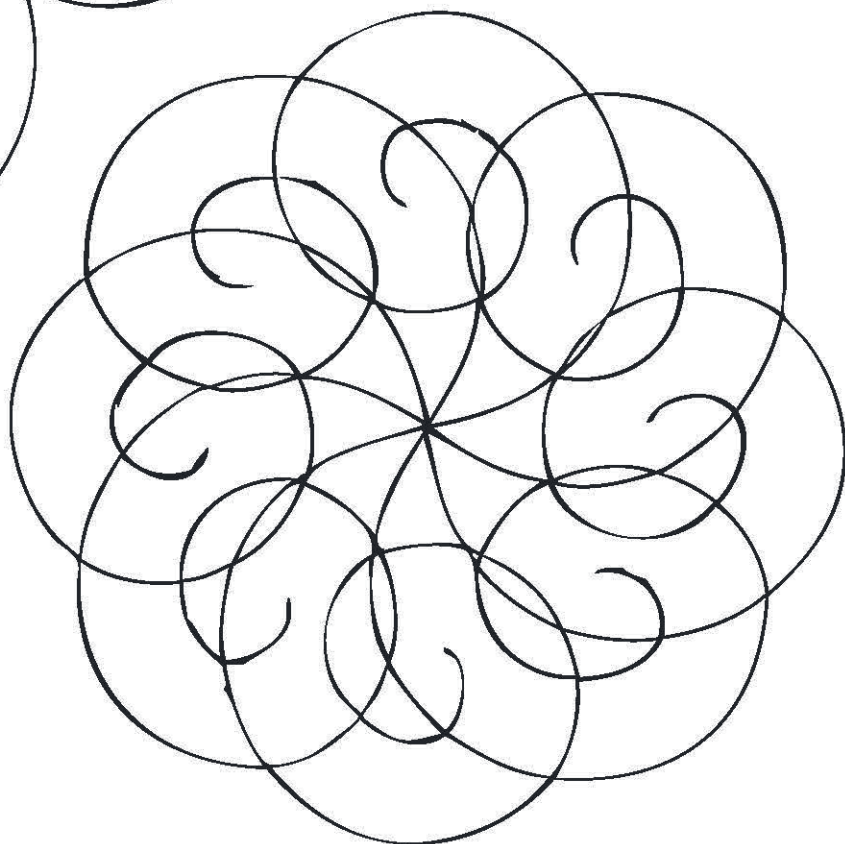

# Welcome to the World of Nautilus Baseline Tools

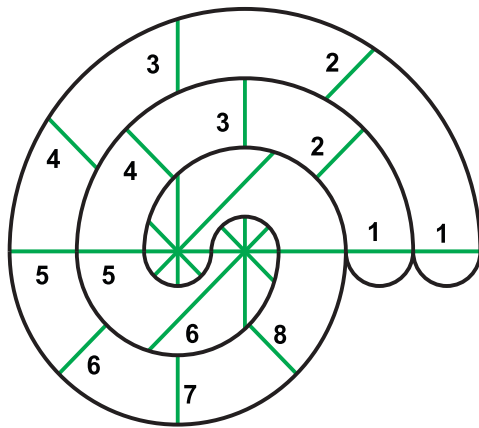

**Nautilus Feather Tool Set**  
3" and 4" Spiral  
QR-NFT

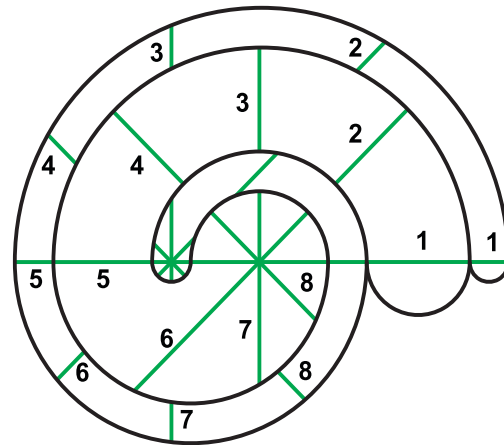

**Nautilus Chunky Feather Tool Set**  
6" and 7" Spiral  
QR-NCT

**Templates are not to  
scale and not actual size**

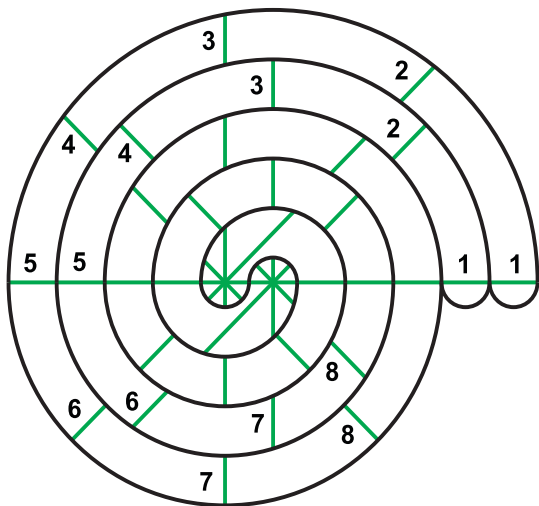

**Nautilus Spiral Tool Set**  
6" and 7" Spiral  
QR-NST

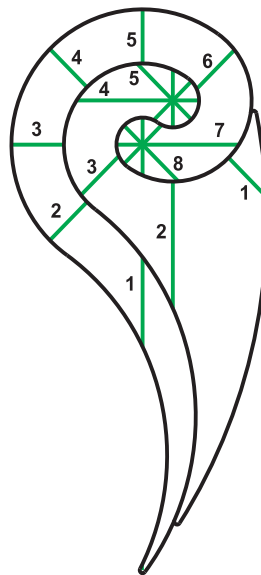

**Nautilus Baby Long Tail**  
6" Long  
QR-NBLT

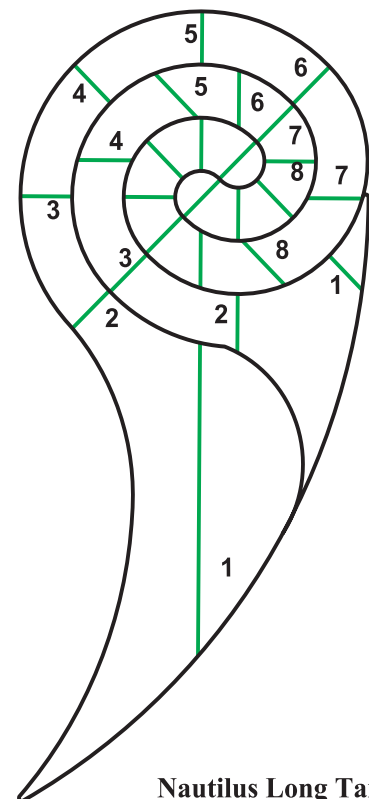

**Nautilus Long Tail**  
8.5" Long  
QR-NLT

## 1 & 5 STRAIGHT BORDER

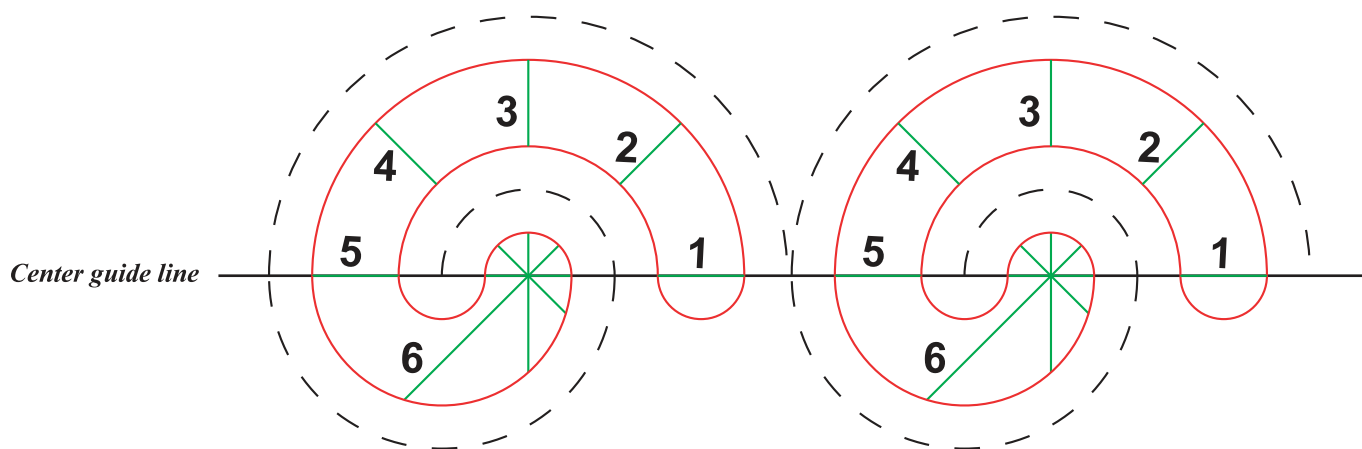

## 1 & 4 ALTERNATING BORDER

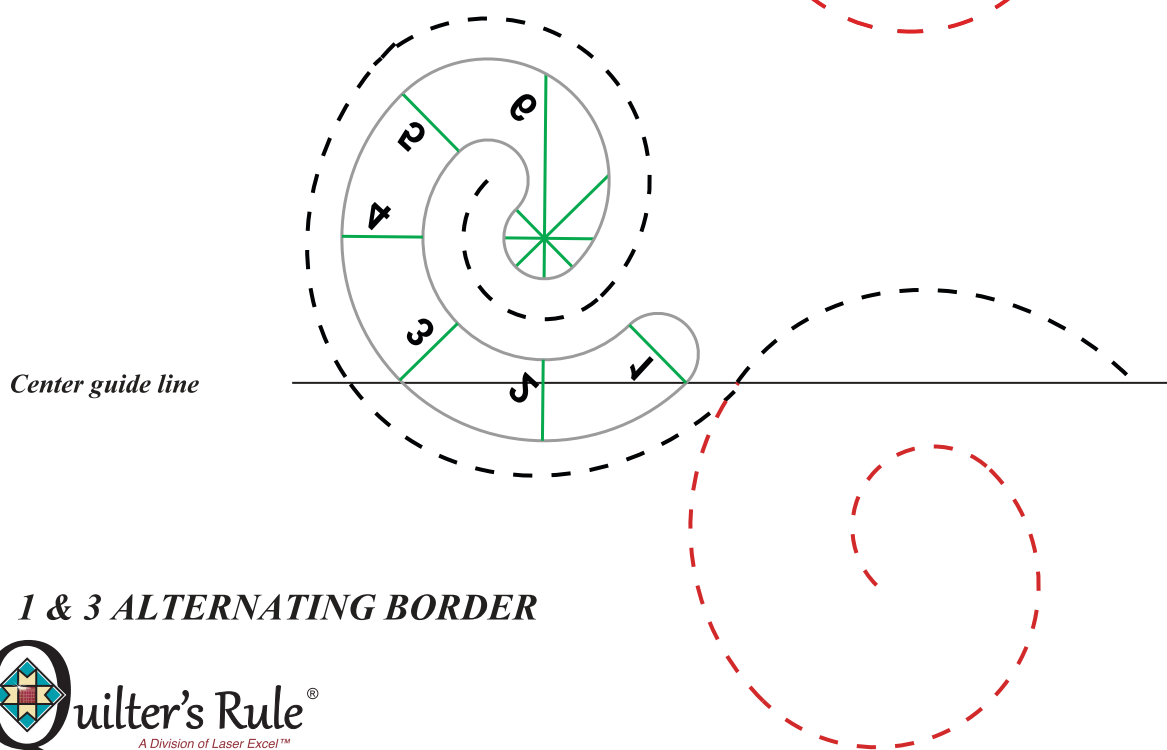
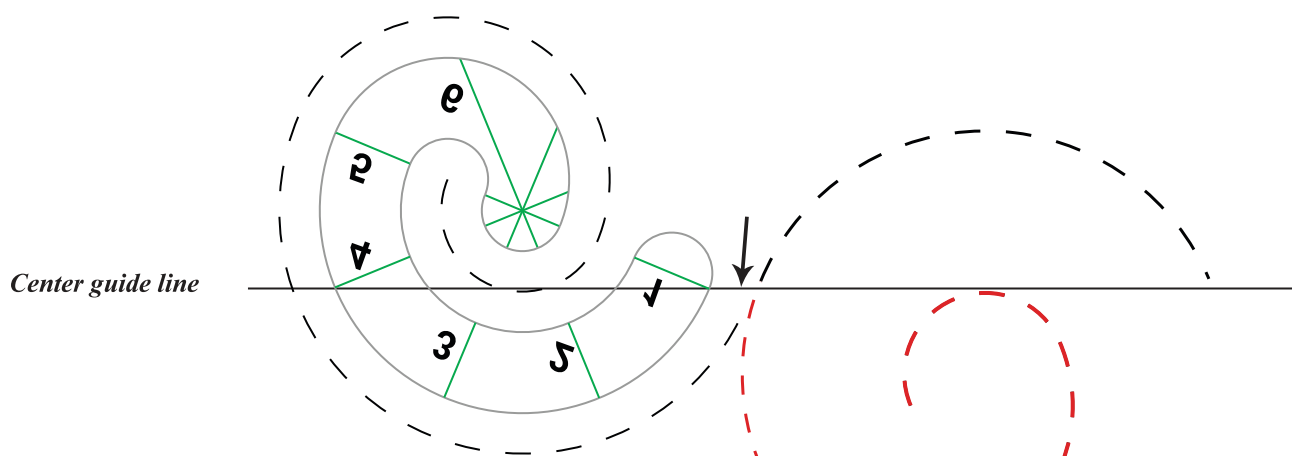

## 1 & 3 ALTERNATING BORDER

Sheri Wood has been machine quilting for over 30 years. She started working with the longarm machine in 2001, and runs the custom quilting service at The Village Smithy Quilt Shop in Bishop Hill, IL. In addition to quilting and developing tools and patterns for quilting; she offers workshops on using the tools and hand dyeing fabrics for quilting. She can be reached at White Robin Designs.

Explore the possibilities with these other Nautilus Baseline Tools

Nautilus Feather Tool Set - 3" and 4"  
Nautilus Feather Chunky Tool Set - 6" and 7"  
Nautilus Spiral Tool Set - 6" and 7"  
Nautilus Long Tail Tool  
Nautilus Baby Long Tail Tool

and more to follow

Additional copies of this booklet and Nautilus Baseline Tools are available from:

***Quilter's Rule***

N6323 Berlin Road  
Green Lake, WI 54941  
(800) 343-8671  
[www.quiltersrule.com](http://www.quiltersrule.com)

***White Robin Designs***

Box 71  
Altona, IL 61414  
(309) 299-8007  
[www.whiterobindesigns.com](http://www.whiterobindesigns.com)